

# BROADBAND PROPAGATION

*Antenna Design & Supply*

1-3 Adelaide Rd. Echunga  
PO Box 529 Echunga  
South Australia. 5153

Phone: (08) 8388 8132  
Fax: (08) 8388 8536  
Intl.Phone: (618) 8388 8132  
Intl.Fax: (618) 8388 8536

ABN: 84 232 273 647

E-mail: [sales@broadbandpropagation.com](mailto:sales@broadbandpropagation.com)  
Web: [www.broadbandpropagation.com](http://www.broadbandpropagation.com)

## VHF/ UHF DISCONE ANTENNA

**Model: BPV-LB-100-400**

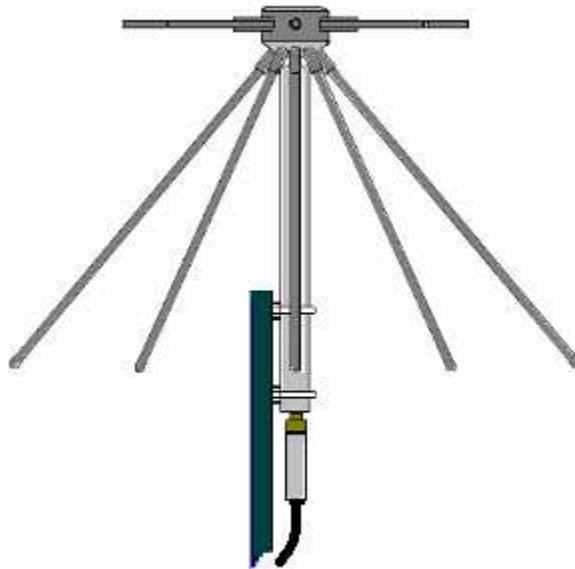

Designed for a variety of base station and tactical applications, the BPV-LB 100-400 is a compact vertically polarised broadband antenna which operates in the frequency range of 100-400 MHz with power handling of 500 watts CW. Mechanical construction of the antenna enables it to withstand the most rugged environmental conditions, with full protection against high wind loads, aggressive salt spray conditions, extreme temperature variation, and wind-borne sand abrasion.

The antenna is pole mounted and can be provided with a range of mounting hardware to suit customer requirements.

Full connector protection can be provided via a gland-entry weather shroud for marine/ salt spray environments (optional)

*\* Lightning and static discharge protection is provided*

### Specifications

<b>Frequency:</b>	<b>100-400 MHz</b>
<b>Gain:</b>	<b>2 dBi typical</b>
<b>VSWR:</b>	<b>Maximum 2:1 across band</b>
<b>Horizontal Pattern:</b>	<b>Omnidirectional</b>
<b>Polarisation:</b>	<b>Vertical</b>
<b>Power Rating :</b>	<b>500 watts average (CW continuous)</b>
<b>Input Impedance:</b>	<b>50 ohms</b>
<b>Input connection:</b>	<b>N type Female</b>
<b>Overall length:</b>	<b>0.8m</b>
<b>Overall Width:</b>	<b>1.3m (ground-plane diameter)</b>
<b>Wind Rating</b>	<b>230 km/hr</b>
<b>Mounting:</b>	<b>Mounts to any circular spigot or tube 30 -50mm Diameter (Or to customer requirement)</b>